

ISOMETRIC VIEW

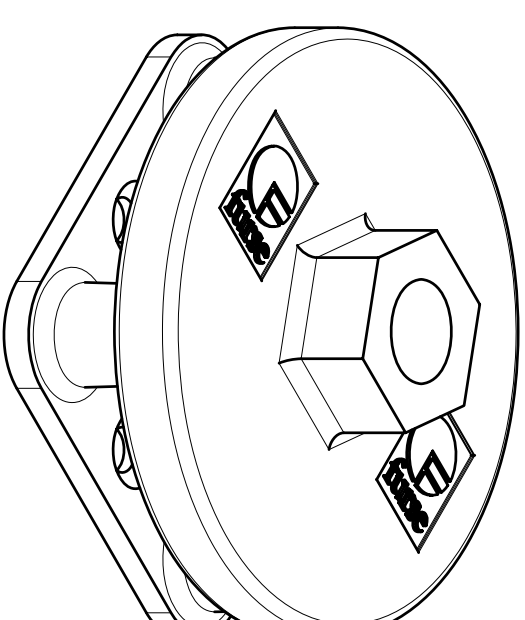

<p>furse Thomas & Betts Nottingham, United Kingdom.</p>		<p>Thomas Betts</p>		<p>TITLE: AIR TERMINAL BASE SUITABLE FOR 15mm DIA ROD TO 25 x3 mm TAPE</p>	
<p>GENERAL NOTES: 1. All dimensions in mm. 2. All undimensioned radii to 1.5r. 3. All dimensions shown are before stated finish. 4. Remove all burrs and sharp edges. 5. The above information applies unless otherwise stated.</p>		<p>MATERIAL: FORGING BRASS CZ132</p>		<p>DWG. NO.: SD105-H</p>	
<p>GENERAL TOLERANCES UNLESS OTHERWISE STATED: ± 0.25</p>		<p>FINISH: SELFCOLOUR</p>		<p>DATE: 17.1.08</p>	
<p>PROJ: FIRST</p>		<p>PROJECT NO:</p>		<p>SCALE: 1:1</p>	
<p>EM. NO: -</p>		<p>SIZE: A3</p>		<p>DRAWN BY: MG</p>	
<p>REV: 0</p>		<p>SHEET: 1 OF 1</p>		<p>CHECKED:</p>	
<p>APPROVED:</p>		<p>APPROVED:</p>		<p>APPROVED:</p>	